



- Since 1946 -

NORTHWEST DOOR®

900 SERIES

INDUSTRIAL STEEL DOORS



NORTHWEST DOOR MEET YOUR SPECIFIC NEEDS.

SUGGESTED SPECIFICATIONS FOR STEEL SECTIONAL OVERHEAD DOORS

NOTE TO SPECIFIERS:

Words in parenthesis indicate frequently specified and highly recommended options

PART 1 GENERAL

1.01 WORK INCLUDED- The sectional doors will be model #924, (#920) manufactured by Northwest Door, Inc. Doors are designed to meet ANSI A216.1-1977 & ANSI/NAGDM 102-1988, as applies.

1.02 RELATED WORK- Opening preparation, miscellaneous or structural metal work, access panels, finish or field painting, field electrical wiring, wire, conduit, fuses and disconnect switches are in the scope of work of other divisions or trades.

PART 2 PRODUCT

2.01 DOOR SECTIONS- Will be roll-formed to a full 2" thickness from hot-dipped, G-6 galvanized steel, 24 GA/#924 (20 GA/#920), per ASTM A-526 standard. Horizontal meeting rails will be rolled-formed with shiplap joint acting as an integral strut and weather joint. Section faces will be deep ribbed for added strength. End stiles shall be "U" shaped, formed from 18 GA galvanized steel and shall completely enclose and protect the end of the door from damage and serve as a flat, smooth surface for exterior weather seal. 18 GA galvanized intermediate stiles shall be permanently attached at each end, as well as at mid-point as required for long life and rigidity. Bottom section will be furnished with a full-width aluminum reinforcing angle/retainer fitted with compressible loop-type weather seal designed for continuous contact at sill.

2.02 FINISH- Exterior and interior door faces will receive a 4-coat protection process. This shall consist of galvanizing, bonderizing, baked-on epoxy basecoat and white polyester topcoat. Total coverage of exterior face will be minimum 1 mil thickness.

2.03 TRACK- All track, vertical mounting angles and brackets will be ASTM A-526 standard commercial quality steel. Minimum track thickness to be 16 GA for 2", 12 GA for 3", G-60 hot-dipped galvanized. Track is 2" standard (3" track recommended on high cycle or doors over 20' wide or 16' high). Vertical track to be graduated, providing an adjustable wedge-type closing action seal with bracket or continuous angle mounting for wood jambs and continuous reverse angle mounting for steel or concrete jambs. Horizontal track will be reinforced with angle of adequate length and gauge to help prevent deflection. Additional field bracing shall be provided by the installer to prevent deflection and establish a rigid installation.

2.04 HARDWARE- All hardware with the exception of rollers, will be made from ASTM A-526 commercial quality steel, coated with hot-dipped galvanizing. Each bottom corner bracket shall be designed to support a dead load equal to three-quarters of the balanced weight. Hinges will be heavy duty, fully gusseted, commercial type. Rollers will have (10) 1/4" ball bearings with hardened inner races. Top fixtures will be fully adjustable for aligning top section with jamb and head. Doors over 16'-3" or 500 lbs. balance-weight, will be furnished with double-end hinges and long-stem rollers. Galvanized steel struts will be provided as required to meet wind load standards ANSI/NAGDM specification 102-1988.

2.05 COUNTER BALANCE- Springs will be torsion type, low stress, helical wound, oil-tempered spring wire per ASTM-229 to provide minimum 10,000 cycles of use or meet specified cycles mounted on a steel shaft; solid CRS or tubular steel. Spring fittings and drums will be made of die-cast, high strength aluminum. Pre-formed galvanized steel aircraft cable shall provide a minimum safety factor of 5:1. (Long life springs of 25,000, 50,000 or 100,000 cycles may be specified and are recommended for high usage applications.)

2.06 WEATHER-STRIPPING- May be specified to greatly reduce air leakage for both insulated and non-insulated doors with complete weather-stripping as follows: (doors will be provided with continuous perimeter seal at jambs, head, sill and with section joint seal. Perimeter seal at jambs and head will be flexible cold weather vinyl designed to continuously contact door exterior in the closed position. Seal at sill will be compressible vinyl designed for continuous contact when door is closed. Section joint seal will be compressible foam rubber attached full length of section edge. All weather-stripping materials will retain sealing properties in sub-freezing and high heat.)

2.07 LOCKS- Designed to engage the vertical track utilizing an end stile-mounted interior slide bolt. (Standard rim cylinder and lock-bar available) Master-keyed cylinders, if required, to be supplied by others.

2.08 WINDLOAD- Door will meet or exceed standards established by ANSI/NAGDM 102-1988 in accordance with ASTM E-330-70.

2.09 OPTIONS-

INSULATION may be furnished with polystyrene or polyurethane core. Back covers over the insulation may be specified of 28 GA, 25 GA or 20 GA pre-painted steel or white HIPS (High Impact Polystyrene Sheeting) may be used for improved insulating characteristics and lightweight durable operation.

FULL VISION SECTIONS may be substituted for one or more sections and may generally be glazed with any glass to 1/2" overall thickness or expanded aluminum for ventilation. Full-vision sections are furnished in mill finish and are not available in a pass door. (Also available in clear and color anodized.)

SECURITY LITES are available in DSB, 1/4" wire glass, 1/8" and 1/4" plexiglass. Lite size measures approximately 5" x 23 1/2".

PASS-THROUGH DOORS available in three or four sections in model #920 doors, up to 14' x 14'. Pass-through doors shall be used in non-insulated doors in low-usage applications only.

CHAIN HOISTS may be furnished as direct-drive up to 14' x 14' or reduced-drive (3:1) for door up to 20' x 14'.

MOTOR OPERATORS are available for all door models and sizes with standard or special controls designed specifically for each application. (Recommended on high usage applications or doors greater than 20' x 14'.)

PART 3 EXECUTION

3.01 INSTALL- Doors shall be installed in accordance with Northwest Door instructions, standards and according to the approved shop drawings. Installation will be by an authorized Northwest Door dealer.

TRACK SYSTEMS

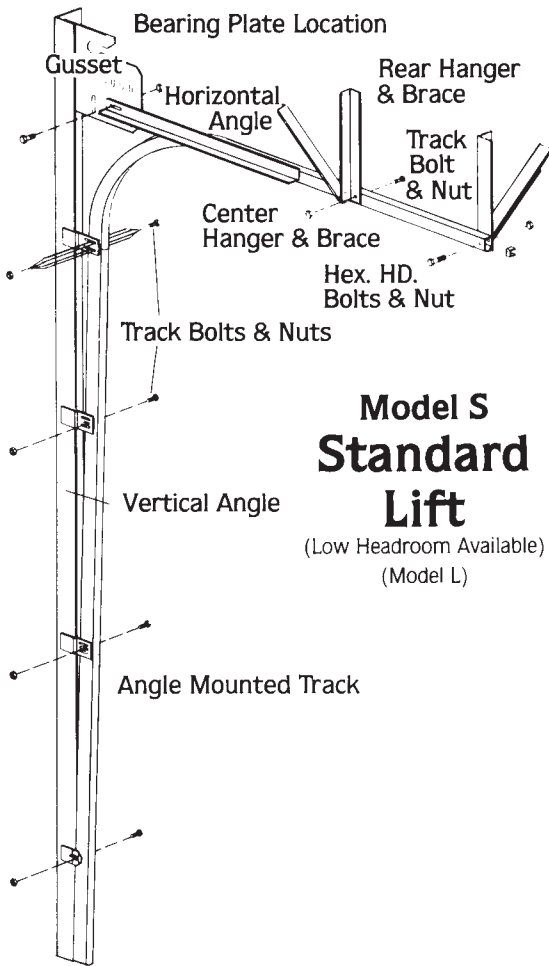

Model S Standard Lift

(Low Headroom Available)
(Model L)

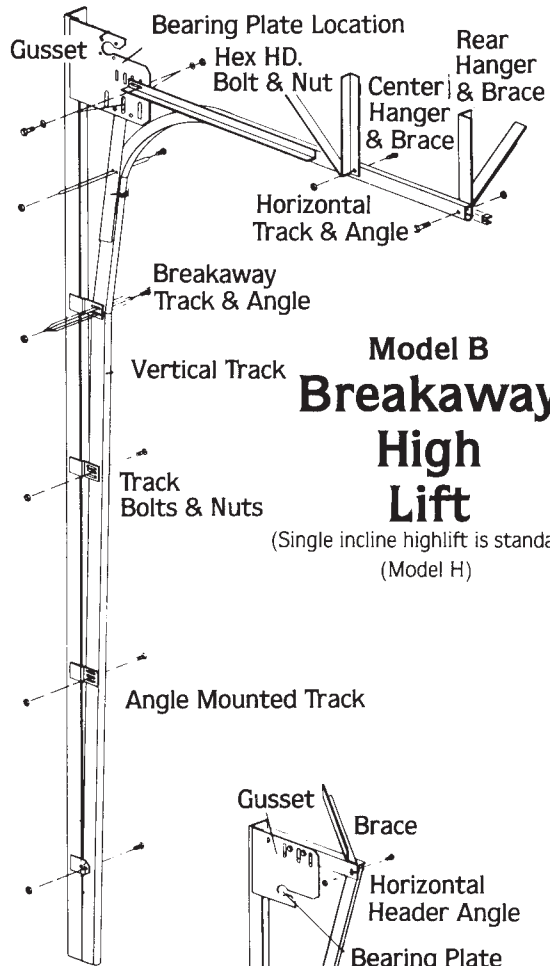

Model B Breakaway High Lift

(Single incline highlift is standard)
(Model H)

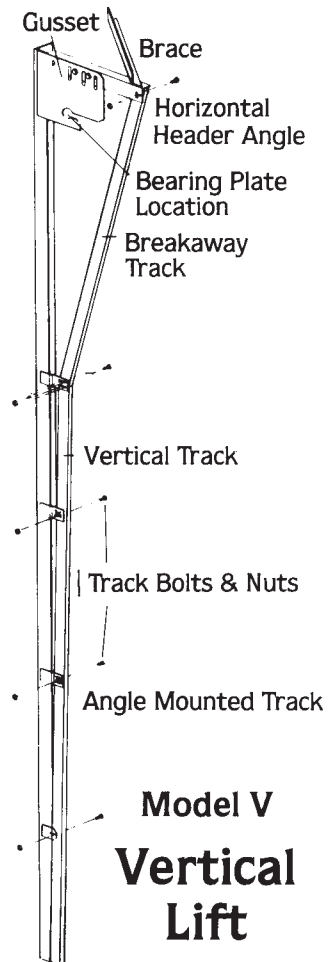

Model V Vertical Lift

Clearance Requirements	Headroom required above opening height		Sideroom for each track	Backroom required
	2" track	3" track		
Standard Lift Model S	16"	18"	5-1/2"	Door height plus 18"
Low Headroom Model L	6-1/2"	9"	5-1/2"	Door height plus 24"
High Lift Standard single incline Model H	Highlift plus 12"		5-1/2"	Door height plus 18" minus high lift
High Lift Optional Breakaway Model B	Highlift plus 9"		5-1/2"	Door height plus 24" minus high lift
Vertical Lift Model V	Door height plus 12"		5-1/2"	18"

Door Width	Glass		Standard Sections
	Openings	Door Height	
Thru - 9'2"	2	7'0" - 8'3"	4
9'3" - 12'2"	3	8'9" - 10'3"	5
12'3" - 16'2"	4	10'6" - 12'2"	6
16'3" - 20'2"	5	12'3" - 14'2"	7
20'3" - 24'2"	6	14'3" - 16'2"	8
24'3" - 28'2"	7	16'3" - 18'2"	9

Insulated Doors

Furnished with polystyrene insulation and a 28, 25 or 20 gauge back panel or polystyrene with white HIPS (High Impact Polystyrene Sheeting) back panel. Polyurethane is available as an option where additional insulating characteristics are required.

Insulation	Back Panel	R*	U*
Polystyrene	Steel	8.1	.123
Polyurethane	Steel	11.5	.087
Polystyrene	HIPS	8.5	.117
Polyurethane	Hips	11.9	.084

*Calculated values based on manufacturers data



DURABLE PRIMER PRE-PAINTED STEEL

Base steel is (1) hot-dipped galvanized, (2) bonderized phosphate treated, then receives a (3) baked-on base coat and a (4) baked-on white top coat of primer for maximum corrosion resistance and providing an excellent base for finish paint.

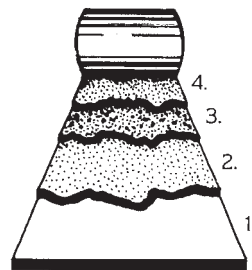

WARRANTY Northwest Door warrants its products to be free of defects in materials for a period of one year after date of shipment from its plant. This warranty is limited to furnishing any part or parts due to product failure during the first year. Northwest Door has sole right to determine whether failure of product is due to product or abuse of product. Warranty does not apply to any product that, in the judgment of Northwest Door, was subjected to misuse or neglect or has been altered during installation in any way that may have impaired its safety, operation or efficiency, nor to any product that has been subjected to an accident. **WARNING:** Any adjustment on your door should be made by an experienced door installer such as your Northwest Door dealer. Serious injury can result from improper adjustments to door hardware. Northwest Door reserves the right to make product changes without prior notice.

LiftMaster Northwest Door recommends LiftMaster®
Professional Line Garage Door Openers on all Northwest Door® garage doors.



NORTHWEST DOOR®
Northwest Door, Incorporated
19000 Canyon Road East - Puyallup, WA 98375-9746
800-522-2264 www.northwestdoor.com

Dealer Name:

